

HM-3ART/LRT

1.2

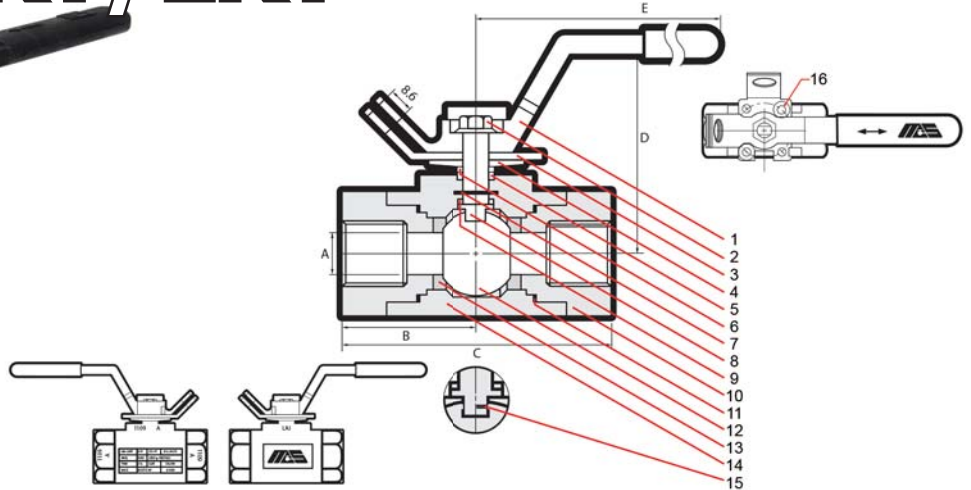

- **Reduced Port / Floating Ball**
- Three Piece Threaded Body
- LF2 & A105N Forged Steel Construction
- NPT Threads to ANSI B1.20.1
- Blowout Proof Stem
- Anti-Static Design
- Positive Lock-Out Device
- **Fire-Safe Certified to API-607 5th Edition**
- Complies with NACE MR-0103 & Supplier Requirements of NACE MR-0175/ISO 15156
- 3000 P.S.I W.O.G.
(Class 1500 Limited) 3/4"-3"

NAME / MATERIAL			
NO.	PART NAME	MATERIAL ART	MATERIAL LRT
1	Handle	Ductile Iron	
2	Handle Nut	A36 C.S. Plated	
3	Gland Flange	A36 C.S. Plated	
4	Belleville Washer	S.S. 301	
5	Packing	Graphite	
6	Gland	Stainless Steel A276 Type 304	
7	Stem O-ring	HNBR (1 1/2" - 3")	
8	Stem	Stainless Steel A276 Type 316	
9	Thrust Washer	Delrin	
10	Cap	Forged Steel A105N	A350 GR LF2
11	Body O-ring	HNBR	
12	Ball	Stainless Steel A351 GR. CF8M (316)	
13	Seat	Delrin	
14	Body	Forged Steel A105N	A350 GR LF2
15	Spring and Pin	Stainless Steel A276 Type 304	
16	Cap Screw	A36 C.S. Plated	

PRESSURE TEMPERATURE RATING

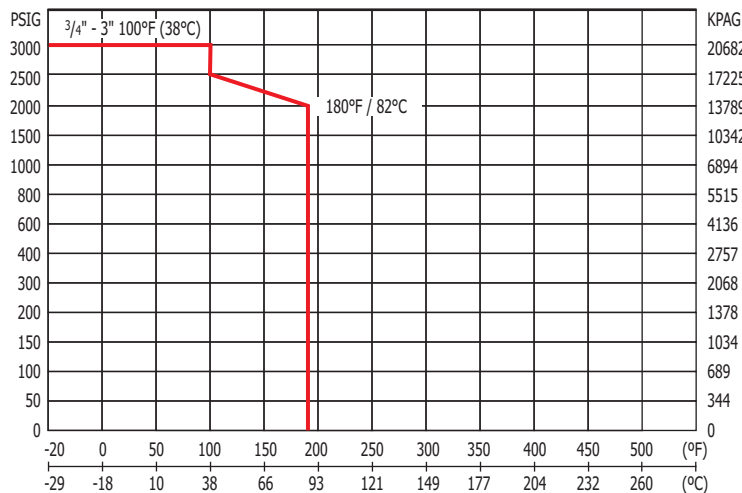

For A105N low temp limit is -20°F (-29°C) For LF2 low temp limit is -40°F (-40°C)

DIMENSIONS						
size	20	25	32	40	50	80
mm/in	3/4	1	1 1/4	1 1/2	2	3
A	12.7	22.2	22.2	32.0	38.1	50.0
mm/in	0.50	0.87	0.87	1.26	1.50	1.96
B	55.5	54.0	76.0	79.5	79.5	127.0
mm/in	2.19	2.13	2.99	3.13	3.13	5.00
C	111.0	108.0	152.0	159.0	159.0	254.0
mm/in	4.37	4.25	5.98	6.26	6.26	10.00
D	83.0	112.0	112.0	138.0	143.0	177.0
mm/in	3.27	4.41	4.41	5.43	5.63	6.97
E	122.0	172.0	172.0	279.0	279.0	302.0
mm/in	4.80	6.77	6.77	10.98	10.98	11.89
CV	15	35	35	100	175	480
Weights	1.22	1.72	2.43	3.70	5.89	15.25
lb/kg	2.69	3.79	5.36	8.16	12.99	33.62