

# F300-SS-F-FS-N

**3.11**

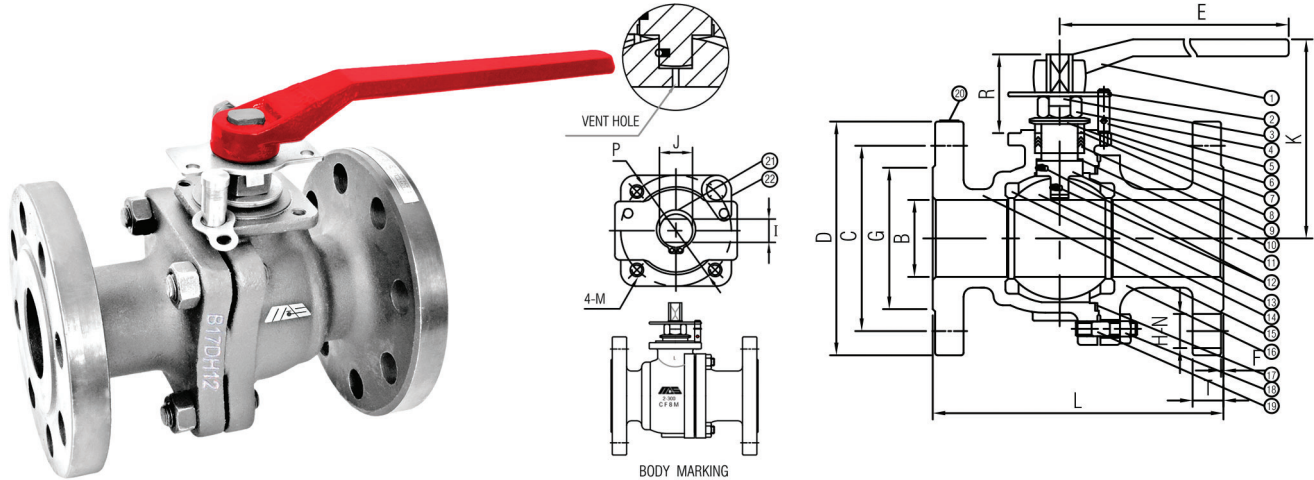

- Full port, Two piece body
- ASME B16.34 Class 300
- Cavty Relief Seat
- Blowout-proof stem
- ISO 5211 Mounting pad
- Floating Ball, Anti-static device
- Open/Closed lockout capability
- **API 607 Fire-safe**
- Complies to NACE MR-0103  
Complies with manufacturer requirements of NACE MR0175/ISO15156

NAME / MATERIAL			
NO.	PART NAME	MATERIAL	QTY
1	HANDLE	DUCTILE IRON	1
2	STOPPER PLATE	A276 TYPE 304	1
3	LOCK WASHER	A276 TYPE 304	1
4	GLAND NUT	A276 TYPE 304	1
5	STOPPER PIN	A276 TYPE 304	1
6	LOCK WASHER	A276 TYPE 304	1
7	BELLEVILLE WASHER	S.S. 301	2
8	GLAND	A276 TYPE 304	1
9	PACKING	GRAPHITE	1 SET
10	THRUST WASHER	RPTFE 15% GFT	1
11	STEM	A276 TYPE 316	1
12	ANTI-STATIC DEVICE	A276 TYPE 304	2 SETS
13	BALL	A351 CF8M	1
14	SEAT	PTFE (TFM-1600)	2
15	BODY	A351 CF8M	1
16	CAP	A351 CF8M	1
17	BODY SEAL	GRAPHITE	1
18	BOLT NUT	A194 GRADE 8MA	1 SET
19	STUD BOLT	A193 GRADE B8M	1 SET
20	IDENTIFICATION PLATE	A276 TYPE 304	1
21	RETAINING RING	CARBON STEEL	1
22	LOCK PLATE	A276 TYPE 304	1

**PRESSURE TEMPERATURE RATING**

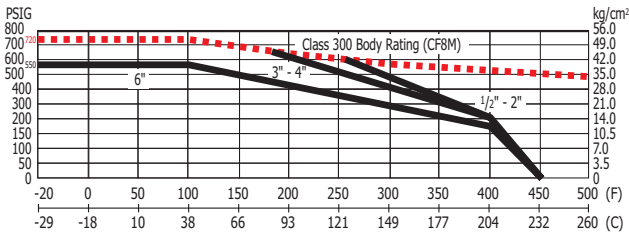

DIMENSIONS																		
SIZE	mm/in B	mm/in C	mm/in D	mm/in E	mm/in F	mm/in G	mm/in H	mm/in I	mm/in J	mm/in K	mm/in L	in M	mm/in N	mm/in P	mm/in T	mm/in R	ISO FLG	WEIGHT KGS/LBS
1/2	15	66.5	95	130	1.6	35	16	8	11	83	140	1/4-UNC	4	36	14.2	27	F03	2.20
	0.59	2.62	3.75	5.12	0.06	1.38	0.62	0.31	0.43	3.27	5.50			1.42	0.56	1.06		4.84
3/4	19	82.5	117	130	1.6	43	19	8	11	86	152.5	1/4-UNC	4	36	15.8	27	F03	3.29
	0.75	3.25	4.62	5.12	0.06	1.69	0.75	0.31	0.43	3.39	6.00			1.42	0.62	1.06		7.23
1	24	89	124	160	1.6	51	19	10	14	104	165	1/4-UNC	4	50	17.5	35.5	F05	4.76
	0.95	3.50	4.88	6.30	0.06	2.00	0.75	0.39	0.55	4.09	6.50			1.97	0.69	1.40		10.47
1 1/2	38	114.5	156	230	1.6	73	22	14	20	125	190.5	5/16-UNC	4	70	20.6	49	F07	9.14
	1.50	4.50	6.14	9.06	0.06	2.88	0.88	0.55	0.79	4.92	7.50			2.76	0.81	1.93		20.10
2	50	127	165	230	1.6	92	19	14	20	134.5	216	5/16-UNC	8	70	22.3	49	F07	12.80
	1.97	5.00	6.50	9.06	0.06	3.62	0.75	0.55	0.79	5.30	8.50			2.76	0.88	1.93		28.16
2 1/2	65	149.4	190.5	400	1.6	104.6	22	17	25	170.5	241.3	3/8-UNC	8	102	25.4	61	F10	22.73
	2.56	5.88	7.50	15.75	0.06	4.12	0.88	0.67	0.98	6.71	9.50			4.02	1.00	2.40		50.00
3	76	168	210	400	1.6	127	22	17	25	181.5	283	3/8-UNC	8	102	28.5	61	F10	29.60
	3.00	6.62	8.27	15.75	0.06	5.00	0.88	0.67	0.98	7.15	11.14			4.02	1.12	2.40		65.12
4	100	200	254	750	1.6	157	22	23	34	205.5	305	1/2-UNC	8	125	31.8	73	F12	50.40
	3.94	7.87	10.00	29.53	0.06	6.18	0.88	0.91	1.34	8.09	12.00			4.92	1.25	2.87		110.88
6	150	270	318	1000	1.6	216	22	27	40	289.5	403	5/8-UNC	12	140	36.6	90	F14	107.3
	5.91	10.63	12.52	39.37	0.06	8.50	0.88	1.06	1.57	11.40	15.87			5.51	1.44	3.54		236.06